

INSTALLATION AND USE

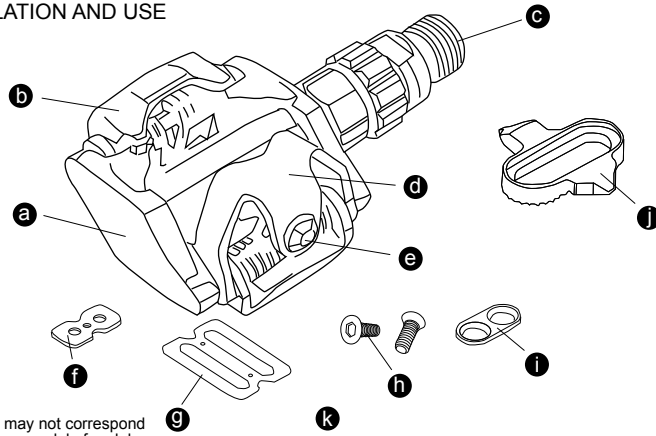

Illustrations may not correspond exactly to your model of pedal

PARTS & TOOLS

PARTS: a. Pedal body b. Front binding (fixed) c. Axle d. Rear binding (adjustable) e. Tension adjuster f. Flat nut x 2 g. Insole washer x 2 h. Cleat bolts x 4 i. Cleat washer x 2 j. Cleat x 2
TOOLS: 6 mm or 8 mm Allen key, (depending on pedal model), 4 mm Allen key, 3 mm Allen key.

A) ATTACH PEDALS TO CRANKS

Exustar pedals have 9/16" x 20T threaded spindles. The right pedal (marked R) is assembled in a clock-wise direction. The left pedal (marked L) is assembled in a counter-clockwise direction.
 1. Lubricate spindle threads prior to assembly. 2. Use a thin 15 mm wrench or 6 mm / 8 mm Allen key for assembly. 3. Tighten well, but avoid excessive force. Recommended torque is 34 Nm (340 kgf/cm).

B) ATTACH CLEATS TO CYCLING SHOES

Take note of the model number of your cleats and consult separate BICYCLE PEDAL SPECIFICATIONS sheet for more information. Left and right cleats are identical - the pointed end faces the toe of the shoe. Some rubber-soled MTB shoes and sandals have a cover over the cleat mounting hole. Use a sharp knife to cut around the outline of the cover, then pull the cover off with a pair of pliers. Your MTB shoes may have built-in insole washers and flat nuts. If so, you will not need these parts. If washers and flat nuts are not built-in, you will need to remove shoe insole and position them inside the shoe to attach cleats.
 1. Lightly lubricate cleat bolt threads with oil. 2. Using the 4 mm Allen key attach cleat bolts and cleat washers loosely to shoe soles. The lateral center line of the cleat should be aligned with the center of the ball of the shoe sole. Adjust vertically via slots in shoe sole. Adjust horizontally via play between cleat washer and cleat. 3. Tighten cleats very firmly, but avoid excessive force. Recommended torque is 5-8 Nm (50-80 kgf/cm). Cleat position can be fine-tuned to preference after trial rides, to preference after trial. It may take some time to find your optimum cleat set-up.

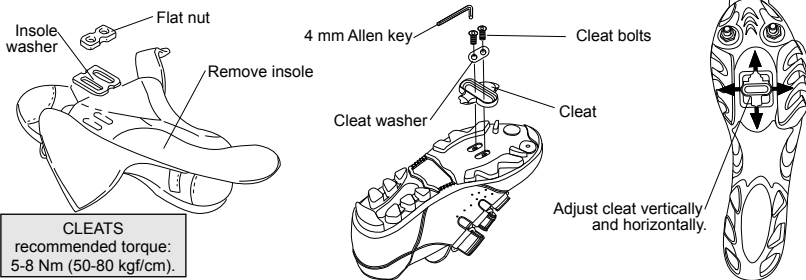

CLEATS
 recommended torque:
 5-8 Nm (50-80 kgf/cm).

C) SHOE/PEDAL USE

To adjust rear binding tension, use a 3 mm Allen key to turn tension adjuster. 1. Increase tension in a clockwise direction (+) (for a more secure shoe/pedal bind, but more difficult engagement and disengagement). 2. Decrease tension in a counter-clockwise direction (-) (for less secure shoe/pedal bind but easier engagement and disengagement). Engage cleated shoes in pedals by aligning the cleat between front and rear bindings while pushing down. Disengage by twisting heel outwards (away from bicycle). Cleat will also release by twisting heel inwards if necessary (for emergency situations only). If you have never used clip-in pedals before, take time to learn how to use them safely. Make sure the tension adjuster is set to the lowest setting. Sit on, or stand over your bike with one foot firmly on the ground. With the other foot, practice engaging and disengaging cleated shoe. When you get used to this, progress to riding slowly in a safe, traffic-free area until engagement and disengagement become natural actions that you can manage easily without looking at your feet. Warning Binding tension should be equal on both pedals to achieve a uniform effect when engaging and disengaging cleated shoes. Minimum tension is recommended for beginners and for rides requiring frequent cleat disengagement, such as in heavy traffic. Do not over-tighten or over-loosen tension adjuster (over tightening may damage thread, and bolt may fall out if too loose).

